



GB-410 SERIES™, GB-414 SERIES™

REBUILDABLE GLYCOL DEHYDRATION PUMPS

GLYCOL DEHYDRATION PUMP GOT YOU DOWN?

STAY UP & RUNNING WITH VIKING GLYCOL PUMPS!

Viking Pump's external gear GB-410 Series™ and GB-414 Series™ products offer a robust and reliable pumping solution, engineered specifically for the rigorous application conditions for triethylene glycol (TEG) natural gas dehydration systems.

FEATURES & BENEFITS

HIGH TEMPERATURE RATING

- All sizes rated to handle temperatures of 350 F to cover upset conditions
- Pumps engineered to handle the high temperature delta between pump & glycol on start-up
 - GB-410 & GB-414 pumps capable of over 225°F temperature differential between pump and glycol temps

ROBUST DURABLE PUMP DESIGN

- Fewer moving wear components for robust, long-lasting field performance
- New advanced hardened materials on critical internal wear surfaces
 - Enhanced wear resistance and durability of dry-run, abrasives, and upset conditions
- Smooth flow with no pulsation dampening equipment required

REBUILDABLE DESIGN

- All wear components are easily replaceable and available in affordable Rebuild Kit
- Simple disassembly & reassembly process for easy field service and repair, saving time and money

RELIABLE MECHANICAL SEAL SOLUTIONS

- Less susceptible to leakage and robust long-lasting design
- Back pull-out seal design allows for easy seal changes in the field
- Axial thrust control standard with single component seal design

EASY FIELD INSTALLATION

- Jaw Type Coupling eliminates the mess and maintenance of an oil bath
- Motor mounting capable for easy drop-in replacement on C-Face motors up to 75 HP
- Motor speed operation eliminates gear reducers or belt drives
- Standard 180 degree SAE ports with bolt-on NPT or Weld-Neck Adapters to accommodate connection type of your choice
- Pump can be plumbed using hard or flexible piping

ALL PUMPS FACTORY TESTED

- Each pump performance and hydro tested with state-of-the-art testing equipment prior to shipment

PUMP RATINGS OF
1500 PSI
AND
350°F

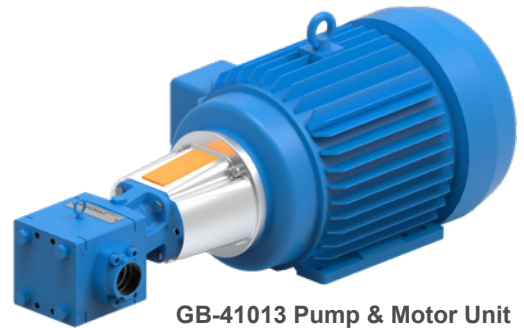

GB-41013 Pump & Motor Unit

TESTIMONIALS

"Viking's engineering team listened to us and was willing to keep trying different things in order to make a pump that can handle the challenges of glycol dehydration... Switching to Viking has been a great success all around. The customers are happy and so are we!"

– Jerry, Service Manager, Marcellus Shale

"Viking has the best customer service I have experienced in the industry. The pumps have performed flawlessly, far better than similar setups. Quick and easy conversion and setup."

– Justin, Facilities Technician Sr., Utica Shale

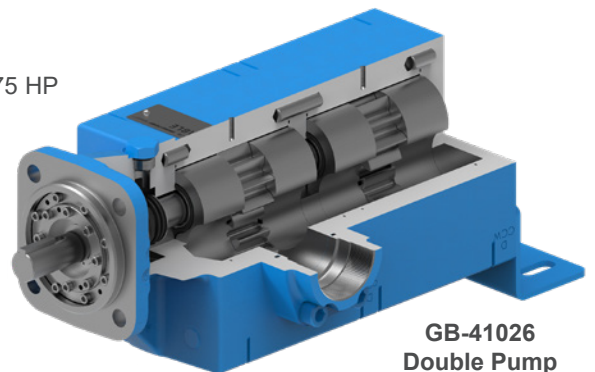

GB-41026
Double Pump

For more information, visit vikingpump.com/GlycolDehy

PERFORMANCE

Pump Model	Port Size & Type	Nominal Flow at 1500 PSI, 1765 RPM on 150°F 8 cPs TEG		Nominal Flow at 1500 PSI, 1765 RPM on 250°F 1.2 cPs TEG		Max Continuous Pressure		Max Recommended Temperature		Approx. Shipping Weight **	
		GPM	GPH	GPM	GPH	PSI	BAR	Deg. F	Deg. C	Lbs.	Kg
GB-41005	2" NPT*	7.9	474	7.6	456	1500	103	350	175	70	32
GB-41007	2" NPT*	11.2	672	10.7	642	1500	103	350	175	72	33
GB-41009	2" NPT*	13.6	816	13.1	786	1500	103	350	175	73	33
GB-41013	2" NPT*	21.2	1272	20.2	1212	1500	103	350	175	77	35
GB-41018	2" NPT*	28.1	1686	26.8	1608	1500	103	350	175	117	53
GB-41022	2" NPT*	36.8	2208	34.6	2076	1500	103	350	175	120	54
GB-41026	2" NPT*	44	2640	40.9	2454	1500	103	350	175	124	56
GB-41415	2" NPT*	39.8	2388	32.4	1944	1500	103	350	175	232	105
GB-41039	2" NPT*	66.8	4008	63.7	3822	1500	103	350	175	170	77
GB-41430	2" NPT*	82.6	4956	67.1	4026	1500	103	350	175	328	149
GB-41445	3" NPT*	128.3	7698	101.9	6114	1500	103	350	175	450	204

* Pumps come standard with NPT adapters bolted on to J518 Code 61 SAE Flange Ports. Butt-Weld/Weld-Neck Bolt-on Adapters also available. ** Weights are with port adapters

THE VIKING PUMP ADVANTAGE

- With over 110 years of experience providing positive displacement pumping solutions, Viking Pump has a rich, lengthy history of providing engineered solutions for tough applications
- Dedicated sales and field support specialists are supported by a team of customer service representatives and engineers
- Knowledgeable team of application engineers available to help with product selection and technical support
- USA based company with vertically integrated manufacturing process



ALL PUMPS FACTORY TESTED

State of the art testing equipment used to confirm performance prior to all shipments



TEST LAB

Our world-class lab gives Viking the ability to test its glycol pump designs across a range of relevant variables



VERTICALLY INTEGRATED PRODUCTION PROCESS

Viking Pump operates a foundry, a 250,000+ sq. ft. machining, assembly and testing center, and an extensive product engineering and testing lab in its world headquarters in Cedar Falls, Iowa, USA. This level of vertical integration ensures maximum quality, ability to satisfy special needs, and to meet project schedules.

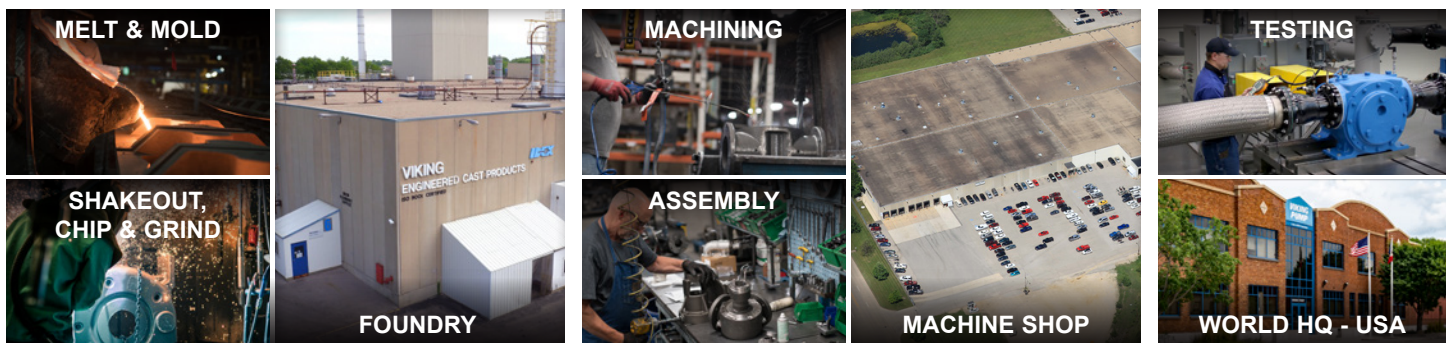

VIKING PUMP, INC.
A Unit of IDEX Corporation
406 State Street
Cedar Falls, Iowa 50613 U.S.A.
vikingpump.com

CONTACT YOUR VIKING PUMP GLYCOL SPECIALIST:

Authorized Distributor Viking Pump

PT ZI-TECHASIA
Address: Menara Jamsostek,
Menara Utara lantai 22, Jakarta Selatan
DKI Jakarta

Mobile/WA : (+62) 813-1891-9776
Office : (+62) 21 5296-2135
Email : ask@dosingpump.co.id

website : www.dosingpump.co.id



vikingpump.com/GlycolDehy

