



34 SERIES™

CAST IRON CONSTRUCTION | ASPHALT PUMP



FEATURES & BENEFITS

- Fully jacketed pump to rapidly deliver heat directly to the stuffing box, casing and head
- Jacketing suitable for hot oil or steam for enhanced application flexibility
- Simple, economical design for transfer and delivery of asphalt and bitumen at low to moderate pressures

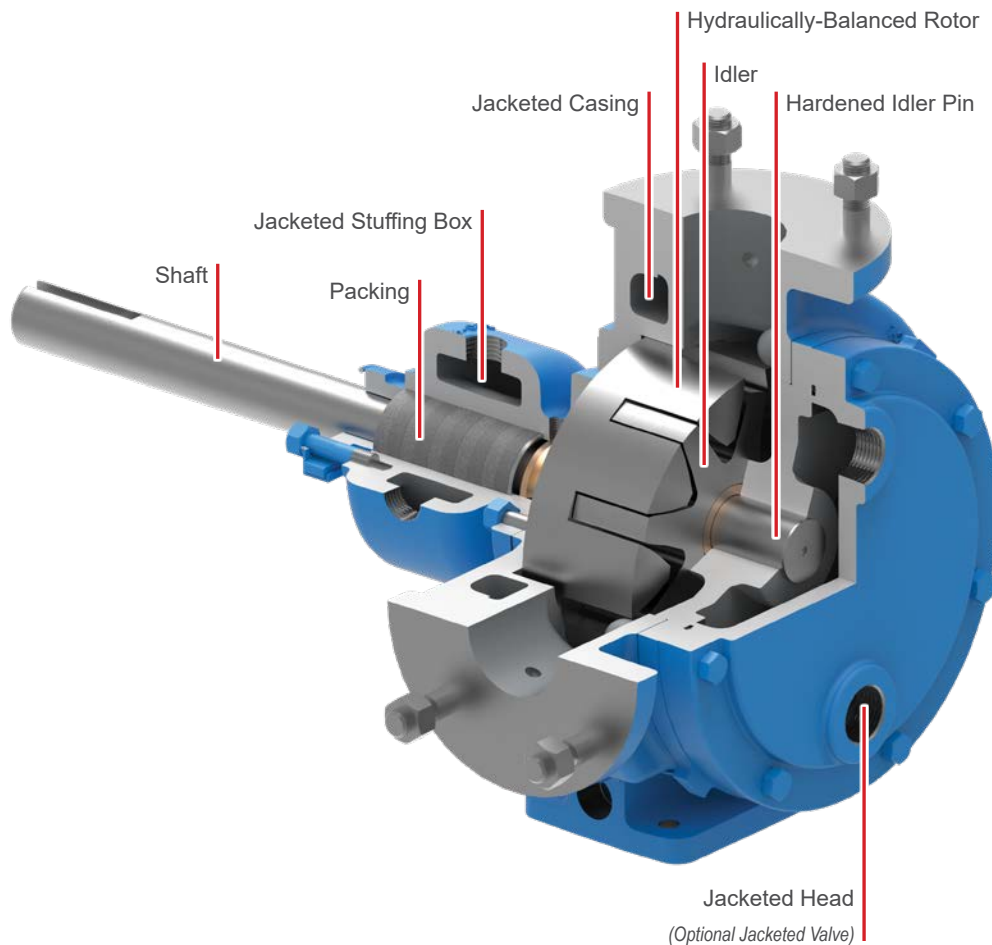

CAPACITY
to 450 GPM
(102 m³/h)



PRESSURE
to 100 PSI
(7 BAR)



VISCOSITY
28 to 250,000 SSU
(1 to 55,000 cSt)



TEMPERATURE
-60°F to +450°F
(-50°C to +230°C)

PERFORMANCE

MODELS	SPECIFICATIONS				
Jacketed	Performance			Standard Ports	
Packing	Max Speed, RPM	GPM	m ³ /h	Size, Inches	Type
LQ34	420	90	20	2.5	Flange
Q34	350	200	45	3	Flange
M34	280	280	64	4	Flange
N34	280	450	102	5	Flange

CURVES

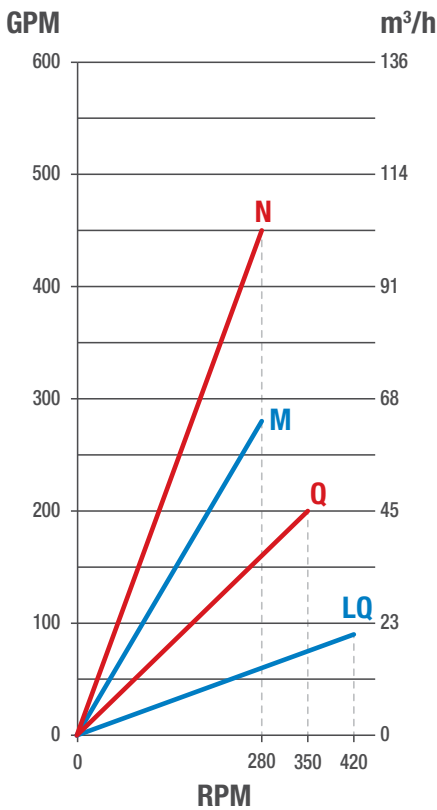

PORTING

- Right Angle (90°)
- Flanged

SEALING

- Packing

MOUNTING

- Foot Mount

OPTIONS

- Jacketed Internal Relief Valve
- Hardened Part Options
- Plain Head for Externally Lubricated Idler Pin

DRIVES

- Offset Gear Reducer Drive
- Purchased Gear Reducer Drive
- V-Belt Drive

TYPICAL APPLICATIONS

- Asphalt
- Bitumen
- Tar
- Pitch
- Bunker Oils
- Residual Oils



VIKING PUMP, INC.
 A Unit of IDEX Corporation
 406 State Street
 Cedar Falls, Iowa 50613 U.S.A.
vikingpump.com

CONTACT YOUR STOCKING DISTRIBUTOR TODAY

Authorized Distributor Viking Pump

PT ZI-TECHASIA
 Address: Menara Jamsostek,
 Menara Utara lantai 22, Jakarta Selatan
 DKI Jakarta

Mobile/WA : (+62) 813-1891-9776
 Office : (+62) 21 5296-2135
 Email : ask@dosingpump.co.id

website : www.dosingpump.co.id

